

**CEMB**<sup>USA</sup><sub>A</sub>

**K10**



**DIGITAL WHEEL BALANCER**

# CEMB BALANCING MACHINES K10

## Features

- Universal space saving wheel balancer with excellent technical specifications combining a sturdy structure with attractive and modern design
- K10 balances steel & light alloy wheels of cars, light trucks, motorcycles & scooters (with optional adaptors)
- Self-Diagnosis and Self-Calibration
- Menu for quick selection of the following:
  - ounces to grams
  - inches to millimeters
  - unbalance threshold 0.1 or 0.25 oz. (1 or 5 g)
- Optimization program for compensation of rim and tire unbalance
- "Static" program--plus 4 ALU programs for PAX, light alloy or special shaped rims
- Manual Data Entry
- Standard Quick Nut Mounting
- One Button Split & Hidden Weight Program
- 6-Compartment Weight Tray
- Unique ABS Base

## Standard Wheel Accessories

- Quick release wingnut with reverse mounting cup & no-mar ring
- 3 cones covering holes 1.69" (43 mm) to 4.33" (110 mm)
- 3 pegs for cone storage
- Rim width gauge for measuring wheel width
- 40 mm threaded shaft

## Technical Specifications

- Power Supply 110 V
- Max. Power Supply absorbed 0.03 Kw
- Shaft Size 40 mm
- Balancing Speed < 100 rpm
- Balancing Accuracy < 1 g
- Rim Diameter 10" - 30"
- Rim Width 1.5" - 20"
- Max Wheel Weight 165 lbs or (75 Kg)
- Operating Temperature 32°-113° F (0°-45° C)
- Average Cycle Time 6 - 8 seconds
- Shipping Dimensions (L 25" x W 43" x H 46")
- Gross Shipping Weight (240 lbs.)



Manufacturer reserves the right to make any and all alterations it may consider suitable without notice.

## CEMB USA BL Systems

2873 Ramsey Road • Gainesville, GA 30501  
Phone: 678-717-1050 • Fax: 678-717-1056  
www.cemb-usa.com • info@cemb-usa.com

## SPLIT & Hidden Weight Program



## Optional Wheel Accessories

- 2 piece truck cone kit fits hole from 3.82" (97mm) to 7.09" (180 mm).
- 3 piece truck cone kit (same as above, but includes, G.G. spacer ring to fit: (Ford F-350, 450, 550)
- 8.5 super cone (for G.M.C.-6500 series & International using 19.5 rims) Note: must be used w/3 piece cone kit
- RL cup (8.11" or 206 mm) for alloy rims (includes no-mar ring)
- SR-USA adaptor (for lug centric wheels)
- Universal bolt pattern adaptor (for wheels with 3-4-5 holes or without center hole)
- Motorcycle adaptor

## K10 Balancing Machine Foot Print

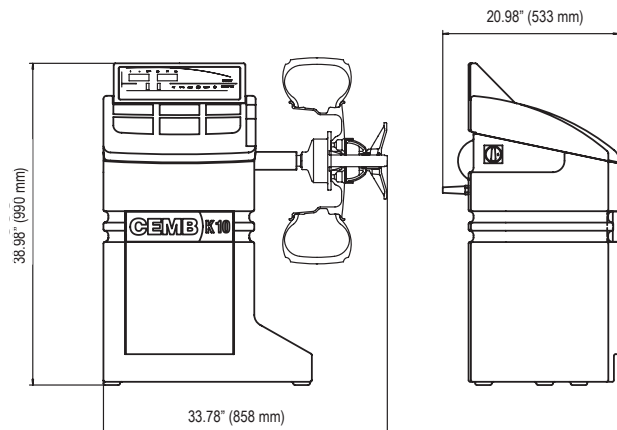

Distributed by:

**Related Models K8 • C29**