

CEMB^{USA}

C212



TRUCK WHEEL BALANCER

CEMB BALANCING MACHINES C212

Features

- Digital Truck Wheel Balancer that operates at high precision on truck, bus, light commercial, and car wheels thanks to a 40mm shaft and to a rich standard equipment including cones and adapters.
- Pneumatic stationary brake useful during wheel mounting and counterweight application. The Powerful and ergonomic (soft) type lift enables excellent centering accuracy of the wheel on shaft.
- C212 balances steel & light alloy wheels of cars, light & heavy commercial trucks and bus
- Multicolored (user friendly) Digital Display Panels
- Pedal Operated Pneumatic Lift
- Fully Automatic Cycle with Breaking
- Shows Static and Dynamic Unbalance
- Optimization Program to compensate the tire unbalance with the rim unbalance
- Self-Diagnosis and Self-Calibration
- Menu for quick selection of the following:
 - ounces to grams
 - inches to millimeters
 - unbalance threshold 0.1 or 0.25 oz. (1 or 5 g)
- One Button Split & Hidden Weight Program
- Automatic Distance and Diameter Entry
- Direct weight location program (no repositioning of stick-on weights)

Technical Specifications

- Power Requirements 110 V
- Max. Power Supply absorbed 0.03 Kw
- Shaft Size 40 mm
- Balancing Speed < 70 rpm truck
- Balancing Speed < 100 rpm car
- Balancing Accuracy < 10 g truck
- Balancing Accuracy < 1 g car
- Rim Diameter 10" - 30"
- Rim Width 1.5" - 20"
- Max Wheel Weight 550 lbs or (250 Kg)
- Operating Temperature 32°-113° F (0°-45° C)
- Average Cycle Time 20 seconds truck
- Average Cycle Time 8 seconds car
- Shipping Dimensions (L 58" x W 43" x H 59")
- Gross Shipping Weight (575 lbs.)

Manufacturer reserves the right to make any and all alterations it may consider suitable without notice.

CEMB USA BL Systems

2873 Ramsey Road • Gainesville, GA 30501
Phone: 678-717-1050 • Fax: 678-717-1056
www.cemb-usa.com • info@cemb-usa.com

SPLIT Program



ALU-S

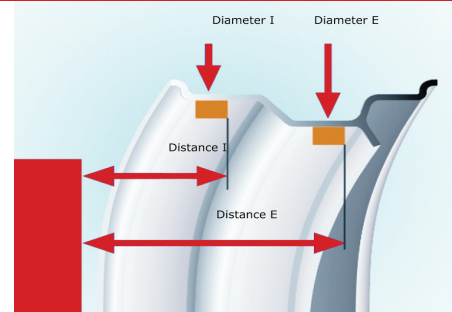

Standard Wheel Accessories

- 8.5 Super Cone (for G.M.C.-6500 series & International using 19.5 rims) Note: must be used w/3 piece cone kit
- 3 Piece Truck Cone Kit (same as above, but includes, G.G. spacer ring to fit: (Ford F-350, 450, 550)
- Standard adapter set with three cones, quick lock nut with hand wheel for wheels with a center hole from Ø from 1.6" to 4.33" (43-110mm).

Optional Wheel Accessories

- Wheel Guard
- SR215/2 stud adapter kit
- Dayton Adaptor 20" - 22.5"
- Dayton Adaptor 22" - 24.5"

C212 Balancing Machine Foot Print

(shown with optional Splash Guard)

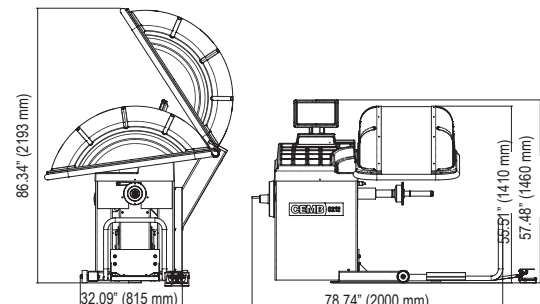

Distributed by:

Related Models C202SE • C206